

Items Supplied

- A Actuator
- B Mounting Screws (x2)
- C Sash Bracket
- D Sash Bracket Screws (x2)
- E Power Loom (2m)
- F Control Loom (2m)
- G Wire Cover
- H Wire Cover Screw
- I Chain Limiter Plug (x2)
- J Chain Limiter Cap
- K Clutch Cap
- L Clutch Tool
- M Pivot Brackets (x2)
- N Pivot Bracket Screws (x4)

Purchased Separately

- O Synchronisation Loom (1.8m)
- Rain Sensor (cable length 2m)
- Network Adaptor (Rain Sensor and Network Adaptor can be seen over the page)

Tools Required

- Marker
- #2 Phillips Screwdriver
- #2 Sq Driver Bit
- Power Drill
- 3mm Drill Bit
- 8mm Drill Bit
- Long Nose Pliers
- Small Flat Screwdriver
- Silicon (if IP rating required)

1 Select Single or Double Actuators Per Window

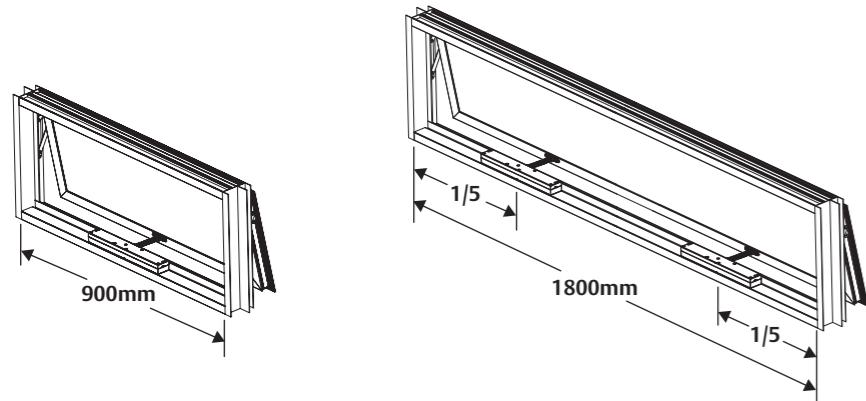

Recommended dimensions only: for further information please visit website assaabloy.co.nz/elevation

Synchronisation: 1 x Synchronisation Loom required for double Actuators. Loom connection as per step 10. Excess cable (up to 300mm) can be stored in the wire cover area up inside the housing. Remove outer sheathing before tightly bunching inside Actuator.

2 Select Chain Exit Height

Fixed Mount Top Chain Exit

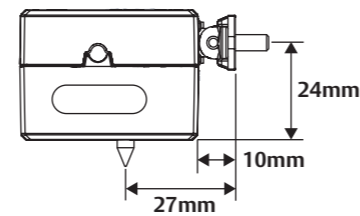

Fixed Mount Bottom Chain Exit

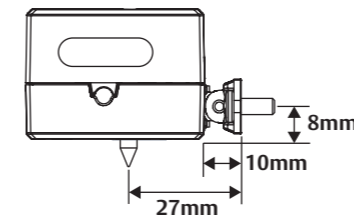

Pivot Bracket Top Chain Exit

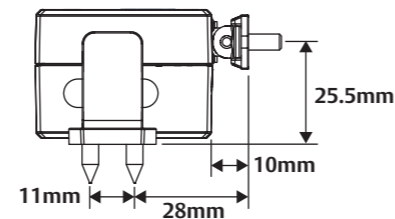

Pivot Bracket Bottom Chain Exit

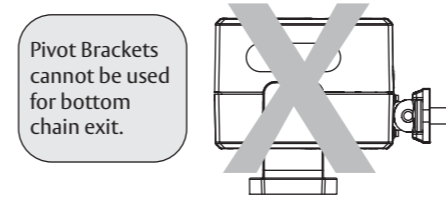

3 Select Fixed or Pivot Bracket Mounting

Fixed Mount

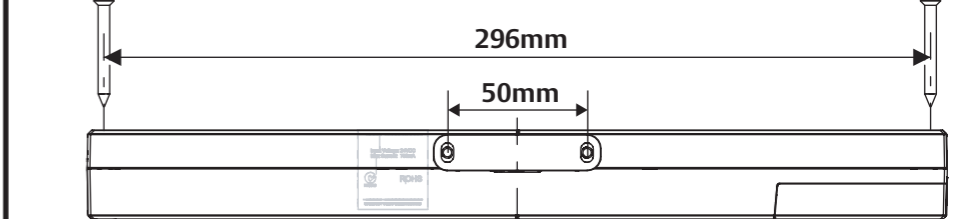

Pivot Mount

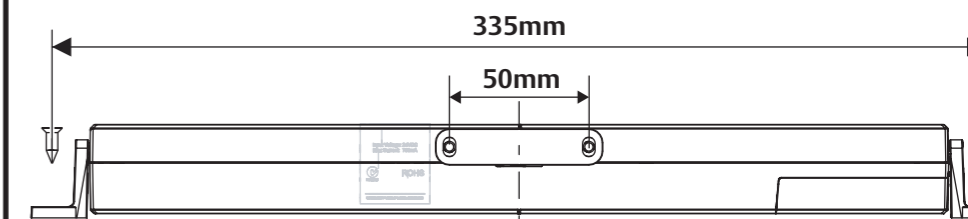

4 Prepare Fixing Holes

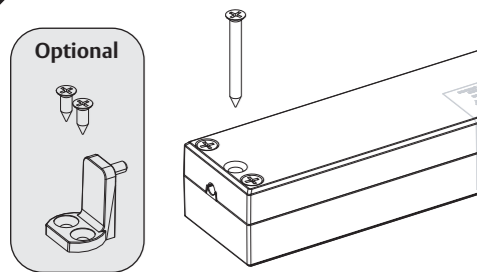

From the dimensional information above, determine mounting requirements. Mark and drill holes to suit.

5 Set Chain Length

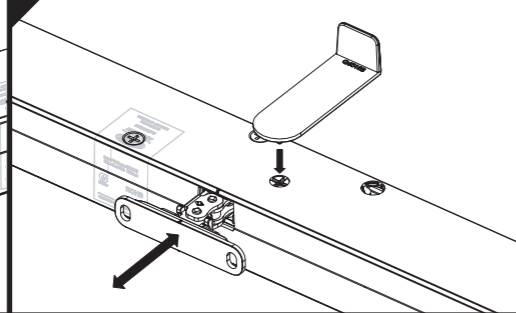

Default chain opening length is 300mm. To adjust the chain opening length, push the Clutch Tool down. The chain can now move in/out.

6 Refer Regulations For Chain Limiting

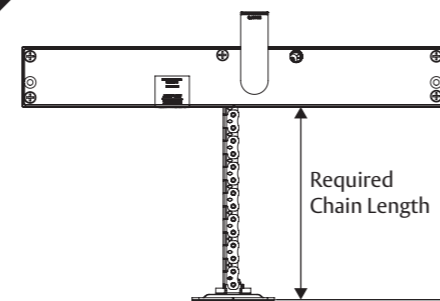

With the Clutch Tool pressed down, pull the chain out to the required length.

7 Move Chain Back 20mm

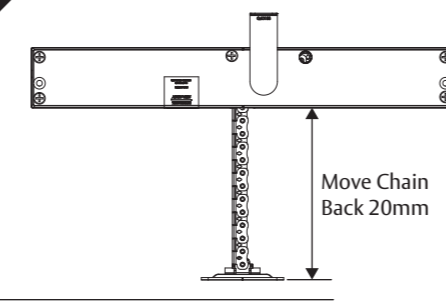

With the Clutch Tool still depressed, retract the chain 20mm from the required length. At the chain limiter hole, locate the nearest hole in the chain link to insert the Chain Limiter Plug.

8 Align Chain Limiter Plug

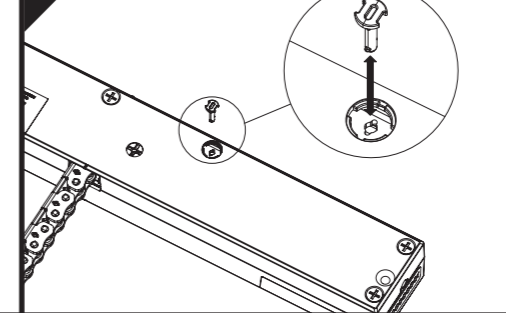

Align the Chain Limiter Plug with the slotted hole in the chain link, then push firmly into place. Rotate 90° to lock into place. To remove, rotate 90° and pull out.

9 Push Chain Limiter Cap

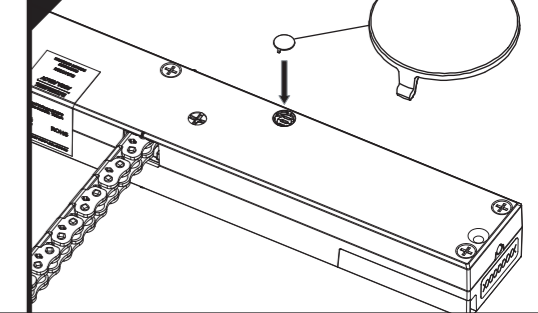

Push the Chain Limiter cap into place. Orientation is specific. Little 'wings' should run across the length of the product.

10 Connect Cables

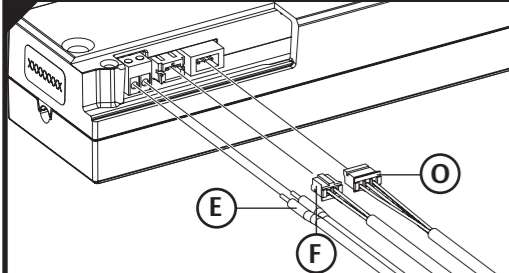

Insert the ⑤ Power Loom, tighten terminal screws. Insert the ⑥ Control Loom, firmly push into place. (Insert ⑦ Synchronisation Loom if required, firmly push into place) **Note:** Synchronisation Loom not supplied.

11 To achieve IP30 rating, seal wire exit points with silicon

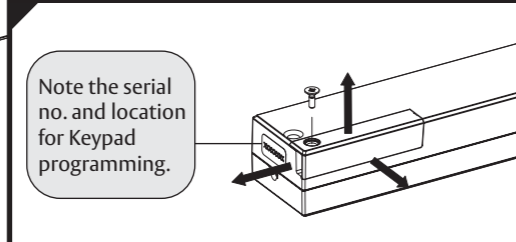

Note the serial no. and location for Keypad programming.

The looms can exit in three different orientations as shown. Pick the best solution for your requirement. Secure Wire Cover in place with small screw supplied. **Note:** Depending on Actuator orientation, this cover may be at the bottom and not as shown.

12 Drill Notches

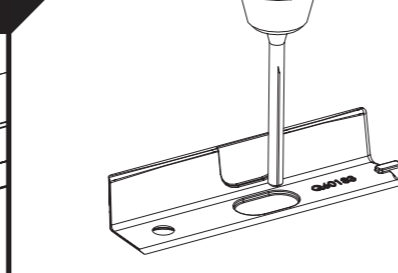

If required, drill out the notches with an 8mm drill bit to best suit your application. If the looms are exiting from the end of the product, no drilling is required.

13 Secure Sash Bracket

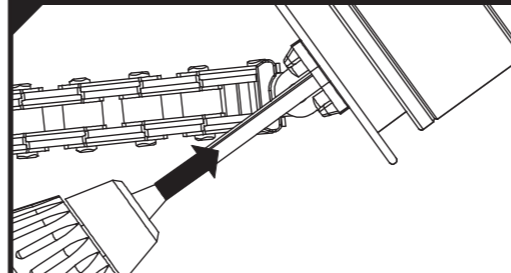

Secure the Sash Bracket to the window sash with screws supplied. Use the Clutch Tool to extend the chain if required. The chain can rotate at the Sash Bracket for ease of access to the fixing screws.

14 Secure Actuator

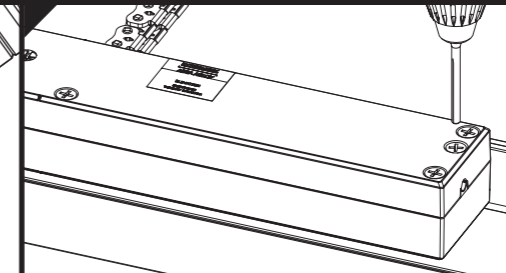

Secure the Actuator to the window sill with screws supplied.
Fixed Mount: 2 x 50mm mounting screws.
Pivot Mount: 4 x 25mm mounting screws.

15 Fit Clutch Cap

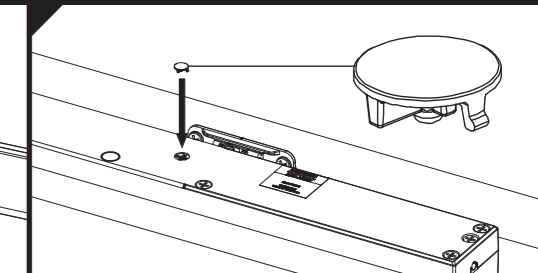

Use the Clutch tool to close window. Push the Clutch Cap into place.

WALL SWITCH CIRCUIT DIAGRAM (Note: for Keypad Circuit Diagram see Keypad fitting instructions)

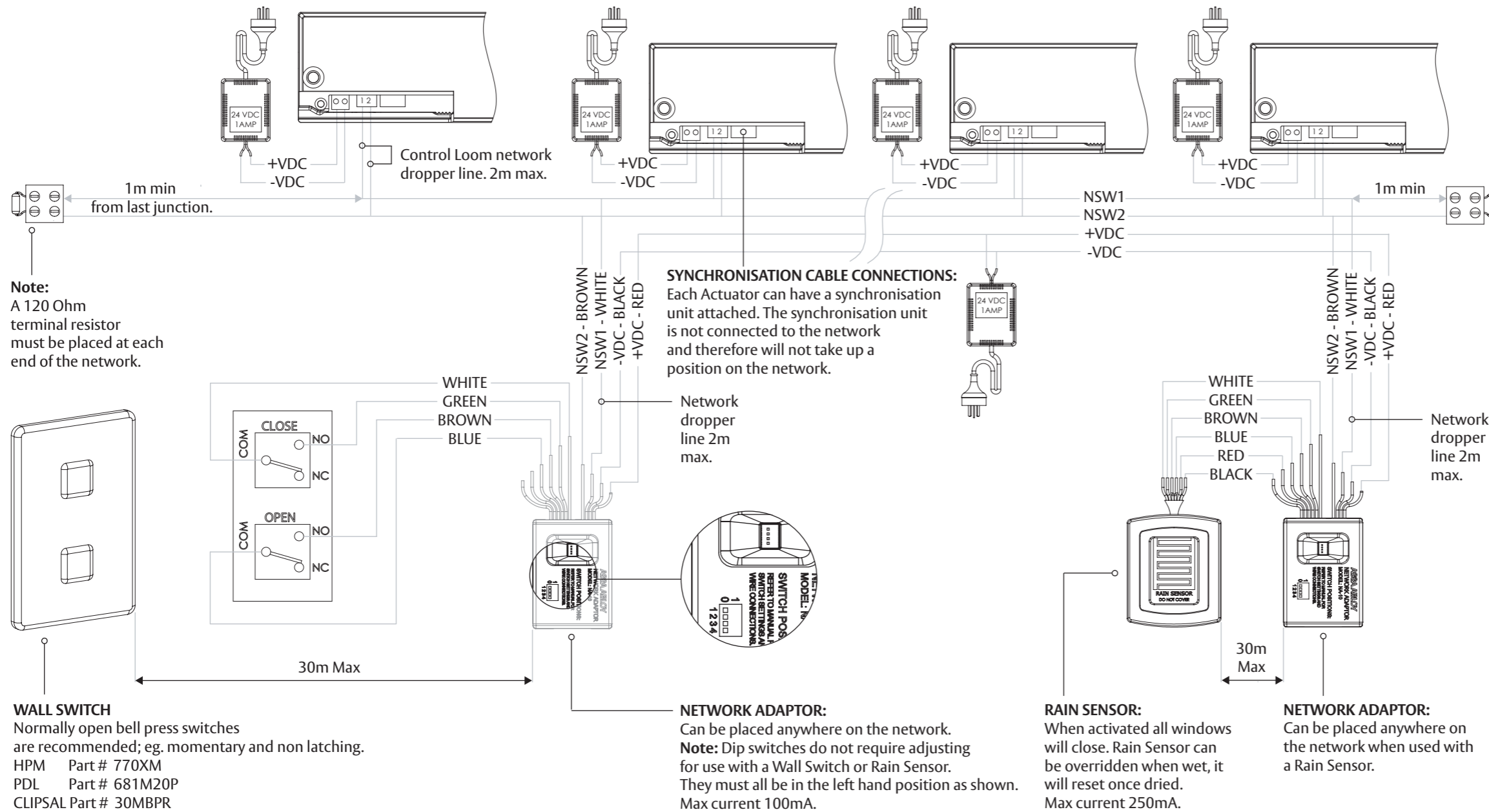

GENERAL NOTES:

1. A maximum of 30 Actuators per network.
2. A maximum of 4 Network Adaptors per network.
3. A maximum of 32 positions can be assigned to one network, each Actuator, and Network Adaptor counts as a position, eg. 30 Actuators and 2 Network Adaptors can be placed on one network.
4. The network cable must be a twisted pair cable. One twisted pair for the network circuit and the other for the 24VDC power circuit.

CALIBRATION AND BASIC FUNCTION

The system must calibrate before use. Power up the system, wait one minute, then press the open switch. The windows will open and close twice. Wait at least one minute before operating the system.
Note: If a window stops during calibration it means that it has safety stopped due to too much load. Press the close switch. Remove the obstruction. Then press the open switch to continue.

Wall Switch Basic Function:
 Press the open switch for at least 2 seconds to open the windows.
 Press the close switch for at least 2 seconds to close the windows.
 Press any switch for at least 2 seconds to stop the windows.

POWER CABLE REQUIRED		
Length (m)	Wire Ø Min	AWG
12	0.7mm	22
19	0.8mm	20
29	1.0mm	18
47	1.3mm	16
74	1.6mm	14
119	2.0mm	12

FINAL CHECKLIST

Ensure:

- Each plug is properly located
- Check that the two Network terminal resistors are installed as shown
- Check **all** connections again
- Check the dipswitches are in the correct position
- Check the power is turned on

TECHNICAL SPECIFICATION	
Input Voltage	24V DC
Maximum Current	750mA per Actuator
Opening Time	Approx 40 sec
Overall Dimensions	308mm x 44mm x 32mm
Operating Temperature	0° - 50°C
Humidity	0% - 95%
Network Cable Length	300m Max

FREQUENTLY ASKED QUESTIONS

- How many items can I run on a 'network' ?**
 The 'network' can handle 32 devices. Each Actuator acts as one device, each Network Adaptor also acts as one device. *The use of synchronisation of two Actuators only counts as one device.*
- Can I use two operators on one window?**
 Yes. The Synchronisation Loom (purchased separately) is required for two Actuators on one window.
- Can I restrict the window opening?**
 Yes. This is done as per step 5 (over page). Any changes to the chain opening length must be done via the chain limiter plug hole.
- How do I know which power lead should go where?**
 The system allows for the power loom to be inserted in either terminal.
- What is the largest sash size for one Actuator?**
 We recommend that the maximum sash width of 900mm and maximum weight of 30kg for one Actuator. A maximum sash width of 1800mm for two Actuators. *Please refer to the web-site for additional information.*
- When do I need to use pivot brackets?**
 The use of pivot brackets is primarily with small height windows (e.g: 300mm). *Please refer to the website for additional information.*
- Can I use more than one Rain Sensor?**
 Yes. You can use up to four Rain Sensors on the one network.
- Can the Rain Sensor control individual windows?**
 No. The Rain Sensor will control all the windows on the network. This can however be achieved with a Keypad network.
- Will all the windows close when the Rain Sensors detect rain?**
 Yes.
- Will my windows re-open automatically once the rain has stopped?**
 No. You will have to press the open button to re-open the windows after the rain has stopped. However, this automatic reopen function is available on a Keypad network.
- Can you override a Rain Sensor that has closed the windows?**
 Yes. However the Rain Sensor will not reactivate until it has dried and reset.

To download simplified Elevation wiring diagrams or additional information please visit www.assaabloy.co.nz/elevation and click on the documents/downloads tab.

